



Naval Tecno Sud
Boat Stand

ATTREZZATURE CANTIERI
NAVALI CERTIFICATE CE

NAVAL TECNO SUD BOAT STAND S.R.L.

Via P. Pascali, 28 - 70010 Valenzano (BA)

P. IVA 08004980721 - Tel. +39 3935493586

navaltecnosud@gmail.com

www.navaltecnosud.it



Naval Tecno sud

CV2T15

Double vertical telescopic boat stand
DOUBLE VERTICAL CRADLE

"SISTEME
DE
CARENAGE"

Puntello verticale doppio, dotato di telescopi e viti di regolazione adatto per Barche a motore, realizzato in portata certificata CE di Ton. 15 + 15 e in varie altezze. Ideale per essere posizionato sui pattini di poppa di piccole, medie e grandi barche a motore, indicato per consentire lo sfilaggio dei carrelli motorizzati avendo l'ingombro dei piedi verso l'esterno. I doppi cappelli con testa a sfera consentono una oscillazione a 360° per meglio adattarsi alle varie inclinazioni di chiglia. Nelle misure più alte può essere usato per **puntellare prua e poppa di Barche a vela**. Articolo molto valido perchè svitando alternativamente le viti di regolazione (alternabilità dei cappelli) consente di portare a termine i lavori in carena. **Personalizzabile a richiesta.**

CV2T Double vertical telescopic boat stand with adjusting screw. Ideal for motorboats. It comes in various sizes and in CE approved working loads of 15+15Tons. Perfect to be placed under the centerline / bow of small, medium and large sized motorboats. As its soleplates are externally oriented, it is well suited to slide motorized boat trailers out. The spherical tilt head allows a 360° oscillation in order to best adjust any position of the tilt head. Larger sized stands can also be used to support both the bow and the stern of sailing boats. It is highly recommended when working under the hull, thanks to the possibility of alternating the position of the tilt heads by alternatively removing the adjusting screws. **Customized on request.**

CARATTERISTICHE - TECHNICAL DATA - CARACTÉRISTIQUES

Portata assiale chiuso: 15 + 15 Ton.
Axial capacity closed:
Capacité fermé:
Portata assiale esteso: 15 + 15 Ton.
Axial capacity extended:
Capacité ouvrir:

Regolazione fine a vite: 150 mm
Fine adjustment screw:
Reglage fin a vis:
Vite di regolazione: M 36 mm
Adjusting screw:
Vis de reglage:

PUNTELLO VERTICALE DOPPIO - DOUBLE VERTICAL BOAT STAND - SUPPORT METALIQUE VERTICAL DOUBLE

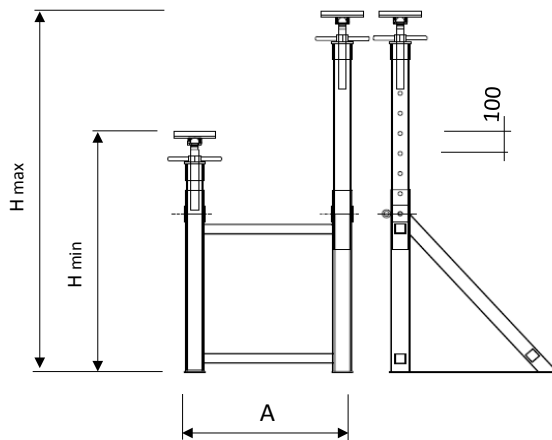
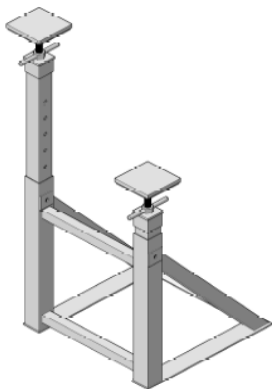

COD.	A	H Min	H Max	Weight Poids
CV2T15 - 08/12	780	800	1200	85
CV2T15 - 10/15	780	1000	1500	95
CV2T15 - 12/18	780	1200	1800	110
CV2T15 - 14/22	780	1400	2200	125
CV2T15 - 16/25	780	1600	2500	140
CV2T15 - 18/28	780	1800	2800	170

FOTO - PHOTOS - PHOTOS

